

# Application Techniques for Automobiles, Vans and Buses

For the most current 3M Technical Information available to successfully use this product, please view this Bulletin electronically and click on the blue underlined links to view the relevant documents.

## 1. General Information

- This Bulletin is specifically for the application of films used for complex contours of automobiles, vans and buses.
- Be sure you obtain and use the most current supporting 3M Product and Instruction Bulletins referenced in this Bulletin.
- Make sure each applicator reads this Bulletin before beginning.
- Follow each step in the order given. Do not take short cuts.

## 2. Pre-installation Inspection Record Requirement

3M requires that a properly executed and signed Pre-installation Inspection Record be completed before any 3M graphics are applied. This record, which identifies any potential problem areas, is mandatory if a warranty claim is made in the future. Make a copy of the appropriate record, located at the end of this Bulletin, for each vehicle.

3M recommends graphics manufacturers clearly define mutual obligations between the vehicle graphics operating companies and themselves and strongly suggests that graphics manufacturers seek written limitations of claims or liabilities on individual vehicles for unsound paint.

## 3. Films and Inks

### A. About Film Memory

Most traditional graphic film has a memory for its original shape. Stretching the film results in some shrinkage as it attempts to return to its original dimensions. As it shrinks, some minor tenting and lifting occurs. Heating traditional film helps relax its memory, which reduces tenting and lifting.

3M's high performance non-PVC, [3M™ Envision™ Print Wrap Film LX480Cv3/SV480Cv3](#), and [3M™ Controltac™ Wrap Film with Comply™ Adhesive IJ380Cv3](#) both feature a 3M technology that significantly reduces its memory once the film is applied and post-heated providing superior conformability and lifting resistance in deep channels or concave areas.

Selected films have superior stretchability and lifting resistance. Film LX480Cv3/SV480Cv3 or IJ380Cv3 with [3M™ Scotchcal™ Gloss Wrap Overlaminate 8548G](#) can be stretched up to 150% (i.e., a 10 inch [25 cm] piece of film can stretch to 15 inches [39 cm]) without using primer or making relief cuts.

When printed with solvent-based inks, [3M™ Controltac™ Graphic Film with Comply™ Adhesive IJ180, IJ180C and IJ180Cv3](#) with [3M™ Scotchcal™ Overlaminates 8518, 8519, 8520, 8915 or 8528](#) can be stretched up to 130% (i.e., a 10 inch [25 cm] piece of film can stretch to 13 inches [33 cm]) without using primer or making relief cuts.

When stretching at beyond these levels, primer and/or relief cuts are required. In general, even when primer is not required, it is good practice to use primer to maximize a graphic's bond to its substrate in any areas where the film will be stretched.

### B. Choosing the Best Film for Application to Contoured Surfaces

Covering complex curves and contours requires special techniques, including heating and stretching the film. The specific characteristics of a film and the inks with which it is printed, as well as whether the shape is concave or convex, determine how well the film stays bonded to the curved substrate. For the best application and removal results, we recommend 3M's 2-mil, removable or changeable graphic films. Two-mil films have less tendency to lift from contoured surfaces. Although all films may tent to some extent when stretched, films with changeable adhesive and all non-cast films tend to tent the most.

Recommended 3M films are listed below. Refer to the 3M Product Bulletin for the films you are using for complete product construction recommendations, warranties and other important information.

Graphics made with the following constructions are not designed to be stretched and are not warranted for use on complex curves, contoured surfaces or deep draws:

- Polyolefin films and overlaminates, including [3M™ Controltac™ Graphic Film 3545C](#) and [3M™ Scotchcal™ Overlaminates 8908 or 8909](#)
- 3M™ Scotchlite™ Reflective Graphic Films (stretching damages the reflectivity)
- Polyester films or overlaminates such as [3M™ Scotchcal™ Overlaminates 8912, 8991 or 8991R](#).

### C. Adhesive Considerations

The 3M recommended films are removable or changeable and have pressure-activated adhesive for easy sliding, tacking, snap up and repositioning until firm application pressure is applied. Many of these films also include 3M's original Comply™ Adhesive as well as Comply™ v2 Adhesive or Comply™ v3 Adhesive, all of which improve speed and ease of application with virtually no trapped air bubbles.

Films with changeable adhesive are typically recommended for applications of less than one year. These films have lower adhesion, usually in the range of 2 to 5 pounds per inch (0.4 to 0.9 kg/cm) peel-back adhesion, which allows the film to be removed easily without the aid of heat or chemicals and without adhesive residue. However, its lower adhesion may result in some lifting of film in areas where the film is highly stretched. In addition, such films may not adhere well to low surface energy (LSE) paints such as on 2007 Ford Econoline vans, Dodge Sprinter vans, etc. These potential application problems are not covered by any 3M warranty.

### D. Effect of Ink on Film's Ability to Stretch

Unprinted films have the most ability to stretch. Graphics printed with most UV inks cannot be stretched as much as graphics printed with most solvent inks without the UV inks showing signs of cracking, which is normal and not covered by the warranty. Keep this in mind when selecting a printing platform. Also read about the effect of using application heat with UV inkjet inks on page 8. Refer to the specific ink and film Product Bulletins for comments on special application techniques or limitations of use.

### E. Relative Stretching Capabilities of Common Wrap Film Graphic Constructions

Note: Graphic constructions not mentioned here are not recommended or warranted for the ability to stretch for typical vehicle wrap installations. It is solely the responsibility of the user to test and approve other constructions.

Note: Use the minimum stretch capability of the components you are using for your graphic construction, found in the 3 tables below.

Ex: If your graphic construction used LX480Cv3 with 8518 and UV ink, your stretching capability would be 130% if you were applying it to a surface that was recommended in the LX480Cv3 Product Bulletin.

Film	Stretching Capabilities <sup>1</sup>
IJ3552C; 3552	<ul style="list-style-type: none"> <li>• Not intended for stretching; use only types of surfaces recommended in the film's 3M Product Bulletin. Will tent over rivets; may lift from corrugations. Using primer helps keep the film from lifting but not the overlaminate. Relief cuts also help prevent lifting or tenting.</li> </ul>
1080; IJ180; IJ180Cv3; IJ181; 180; 180C; 181	<ul style="list-style-type: none"> <li>• Stretches up to 130% of the original dimension when the radius of the channel is 1/4 inch (6 mm) or less without using primer or making relief cuts.</li> </ul>
LX480Cv3/SV480Cv3; IJ380Cv3	<ul style="list-style-type: none"> <li>• Stretches up to 150% of the original dimension when the radius of the channel is 1/4 inch (6 mm) or less without using primer or making relief cuts.</li> </ul>

<sup>1</sup> **Example of 150% Stretch:** A 10 inch [25 cm] piece of film can stretch to 15 inches [39 cm].

**Example of 130% Stretch:** A 10 inch [25 cm] piece of film can stretch to 13 inches [33 cm].

Stretching beyond these points requires the use of primer and relief cuts.

Graphic Protection	Stretching Capabilities
Graphic Protection other than what is listed below	<ul style="list-style-type: none"> <li>Not intended for stretching; use only types of surfaces recommended in the film's 3M Product Bulletin. Will tent over rivets; may lift from corrugations. Using primer helps keep the film from lifting but not the overlaminate. Relief cuts also help prevent lifting or tenting.</li> </ul>
1920DR; 8530; 8518; 8519; 8520 8528; 8915	<ul style="list-style-type: none"> <li>Stretches up to 130% of the original dimension when the radius of the channel is 1/4 inch (6 mm) or less without using primer or making relief cuts.</li> <li>Stretching more than 130% may cause the overlaminate to lift, even if primer was used with the base film.</li> </ul>
9740i <sup>2</sup> ; 9730UV <sup>2</sup> ; 9800CL <sup>2</sup>	<ul style="list-style-type: none"> <li>Stretches up to 130% of the original dimension when the radius of the channel is 1/4 inch (6 mm) or less without using primer or making relief cuts.</li> <li>Stretching more than 130% may cause the UV clear coat to crack; the use of primer has no impact on this.</li> </ul>
8548G, 8549L	<ul style="list-style-type: none"> <li>Stretches up to 150% of the original dimension when the radius of the channel is 1/4 inch (6 mm) or less without using primer or making relief cuts.</li> <li>Stretching more than 150% may cause the overlaminate to lift, even if primer was used with the base film.</li> </ul>

<sup>1</sup> **Example of 150% Stretch:** A 10 inch [25 cm] piece of film can stretch to 15 inches [39 cm].

**Example of 130% Stretch:** A 10 inch [25 cm] piece of film can stretch to 13 inches [33 cm].  
Stretching beyond these points requires the use of primer and relief cuts.

<sup>2</sup> To achieve stretching capability with 9740i, 9730UV, or 9800CL you have to follow optimal processing conditions.

Inks	Stretching Capabilities
Most UV Inkjet Printed Inks	<ul style="list-style-type: none"> <li>Stretches up to 130% of the original dimension when the radius of the channel is 1/4 inch (6 mm) or less without using primer or making relief cuts.</li> <li>Stretching more than 130% may cause UV inks to crack; the use of primer has no impact on this.</li> <li>Stretching more than 130% may cause the overlaminate to lift, even if primer was used with the base film.</li> </ul>
Most Solvent Inkjet Printed Inks	<ul style="list-style-type: none"> <li>Stretches up to 200% of the original dimension when the radius of the channel is 1/4 inch (6 mm) or less without using primer or making relief cuts.</li> <li>Stretching more than 200% may cause Solvent ink to lighten; the use of primer has no impact on this.</li> </ul>
GSLXr SuperFlex Ink	<ul style="list-style-type: none"> <li>Stretches up to 200% of the original dimension when the radius of the channel is 1/4 inch (6 mm) or less without using primer or making relief cuts.</li> <li>Stretching more than 200% may cause the SuperFlex ink to crack; the use of primer has no impact on this.</li> </ul>

<sup>1</sup> **Example of 150% Stretch:** A 10 inch [25 cm] piece of film can stretch to 15 inches [39 cm].

**Example of 130% Stretch:** A 10 inch [25 cm] piece of film can stretch to 13 inches [33 cm].  
Stretching beyond these points requires the use of primer and relief cuts.

Note: The following products are mentioned above. Click the blue underlined links to go to the 3M Product Bulletin.

[3M™ Envision™ Print Wrap Film LX480Cv3/SV480Cv3](#)

[3M™ Controltac™ Wrap Film with Comply™ Adhesive IJ380Cv3](#)

[3M™ Wrap Film Series 1080](#)

[3M™ Controltac™ Graphic Film IJ181](#)

[3M™ Controltac™ Graphic Film 181](#)

[3M™ Scotchcal™ Gloss Wrap Overlaminate 8548G](#)

[3M™ Scotchcal™ Luster Wrap Overlaminate 8549L](#)

[3M™ Screen Print UV Gloss Clear 9740i](#)

[3M™ Controltac™ Graphic Film Series 180 and Graphic Film with Comply™ Adhesive Series 180C](#)

[3M™ Controltac™ Graphic Film IJ180 and Graphic Film with Comply™ Adhesive IJ180C or IJ180Cv3](#)

[3M™ Controltac™ Changeable Graphic Film with Comply™ Adhesive IJ3552C](#)

[3M™ Controltac™ Changeable Graphic Film with Comply™ Adhesive IJ3552C](#)

**F. Films Recommended for Short to Long Term Applications**

**Screen Printing**

- [3M™ Controltac™ Graphic Film Series 180](#)
- [3M™ Controltac™ Graphic Film with Comply™ Adhesive Series 180C](#)
- [3M™ Controltac™ Graphic Film with Comply™ v2 Adhesive Series 180Cv2](#)
- [3M™ Envision™ Print Wrap Film LX480Cv3/SV480Cv3](#)

**Inkjet Printing**

- [3M™ Controltac™ Graphic Film IJ180-10](#)
- [3M™ Controltac™ Graphic Film with Comply™ Adhesive IJ180C-10](#)
- [3M™ Controltac™ Graphic Film with Comply™ Adhesive IJ180Cv3-10](#)
- [3M™ Controltac™ Wrap Film with Comply™ Adhesive IJ380Cv3](#)
- [3M™ Envision™ Print Wrap Film LX480Cv3/SV480Cv3](#)

**G. Films Recommended for Applications of LESS Than One Year**

**Screen Printing**

- [3M™ Controltac™ Changeable Graphic Film Series 3552C](#)

**Inkjet Printing**

- [3M™ Controltac™ Changeable Graphic Film with Comply™ Adhesive IJ3552C](#)

**4. Health and Safety**



**CAUTION**

---

When handling any chemical products, read the manufacturers' container labels and the Safety Data Sheets (SDS) for important health, safety and environmental information. To obtain SDS sheets for 3M products go to [3M.com/SDS](http://3M.com/SDS), or by mail or in case of an emergency, call 1-800-364-3577 or 1-651-737-6501.

When using any equipment, always follow the manufacturers' instructions for safe operation.

---



**CAUTION**

---

Any activity performed for a long period of time in an awkward position or with a high amount of force is potentially a risk for causing musculoskeletal strain, pain or injury. When applying graphics, follow these practices to improve comfort and avoid injury:

- Alternate your tasks during the application.
  - Schedule regular breaks.
  - Perform stretches or do exercises to improve circulation.
  - Avoid awkward reaching.
- 

**Air Quality Regulations**

State Volatile Organic Compound (VOC) regulations may prohibit the use of certain cleaning chemicals with VOC's in graphic arts coatings and printing operations. For example, the California South Coast Air Quality Management District prohibits use of certain solvent-based solutions without a permit and other California AQMD's prohibit use of certain solutions without a permit or a regulatory exemption. Check with your State environmental authorities to determine whether use of this solution may be restricted or prohibited.

**5. Surface Preparation**

**A. Clean the Surface**

All substrates must be considered contaminated. Clean the substrate immediately before applying the film. Dust and other contaminants can collect quickly on the substrate and prevent the film from adhering properly. Even a freshly painted substrate can collect dust before graphics can be applied.

1. Use a solution of 1 ounce of liquid dishwashing detergent, such as Joy® or Dawn®, per gallon of lukewarm water to thoroughly clean the vehicle. Rinse with water.
  - Avoid soaps or preparations that contain waxes, oils or lotions; some window cleaners contain waxes!
  - Be aware that the chemicals used in some automated vehicle washing equipment may prevent good film adhesion.
  - Pay particular attention to cleaning the front and rear of the vehicle, which tend to have more dirt, oil and dead insects.

2. Dry the surface thoroughly with clean, lint-free paper towels. A heat gun may be used to apply moderate heat and accelerate the drying.
  - Moisture prevents the adhesive from adhering correctly, can cause bubbles, and can freeze in cold environments. Any moisture trapped beneath the graphic will cause the graphic to fail prematurely.
  - Moisture on the substrate results from:
    - Inadequate drying after cleaning as well as from application solutions.
    - Condensation at low temperatures.
    - High humidity environments.
3. Wipe the surface again with a solvent-based cleaner. Refer to the list of cleaners, below. Be sure that the cleaner does not damage the vehicle's paint.
 

Note: Car wax can greatly reduce graphic adhesion. Solvent-based cleaners must be used to thoroughly remove any wax residue. Alcohol-based cleaners do *not* remove wax as effectively.

  - a. Saturate a clean paper towel with the cleaner.
  - b. With the saturated towel, wipe the surface where the graphic will be installed and one foot (30 cm) beyond this area.
  - c. Before the cleaner evaporates from the substrate, wipe the surface with a dry, lint-free paper towel. As the paper towel becomes dirty, discard it. A dirty towel will simply move the dirt around, rather than remove it.
  - d. Make sure the substrate is completely dry. If necessary, use a heat gun to dry any retained moisture.
4. Repeat Step 3 using isopropyl alcohol (IPA) as the cleaner.
  - If using industrial grade IPA, mix a solution of 2 parts IPA to 1 part water.
  - If using 70% rubbing alcohol, do not dilute it.

Note: IPA evaporates very quickly. Always wipe the surface before it evaporates. The evaporation rate increases in warm and/or windy environments.
5. Apply the graphic immediately. Dust and contaminants prevent the adhesive from performing as expected.

## B. Cleaning Products and Tools

This list of cleaners is provided for your convenience; other acceptable cleaners may be available. 3M does not endorse any particular chemical manufacturer or supplier.

### (1) Lower Solvent Content Cleaners

- 3M™ Prep Solvent-70, 8983 <sup>1</sup>
- Other suitable products may be available from your local building products store.

### (2) Petroleum Distillate-based Cleaners

- 3M™ Adhesive Cleaner and Wax Remover 8984 <sup>1</sup>
- DuPont Prep-Sol™ Solvent Cleaner 3919S <sup>2</sup>
- Sherwin Williams R7K156 Sher-Will-Clean™ <sup>2</sup>
- Sherwin Williams R7K158 Sher-Will-Clean™ <sup>2</sup>

### (3) Application Tools

- 3M™ Plastic Applicator (squeegee) PA-1<sup>1</sup>
- 3M™ Low Friction Sleeve SA-1<sup>1</sup> *Use a low friction sleeve on the plastic applicator to minimize the possibility of surface scratching.*
- 3M™ Rivet Brush RBA-1 or RBA-3 <sup>1</sup>
- 3M™ Air Release Tool 391X <sup>1</sup>
- 3M™ Scotchmate™ Reclosable Hook and Loop Fastener - Loop portion SJ-3523 <sup>1</sup> *apply to applicator PA-1 as an alternate to sleeve SA-1*
- 3M™ Tape Primer 94 <sup>1</sup>
- 3M™ Vehicle Channel Applicator Tool VCAT-2 <sup>1</sup> *See page 7 for information.*
- 3M™ Roller L and Roller S <sup>1</sup> *See page 6 for information.*
- 3M™ Citrus Base Industrial Cleaner <sup>1</sup>

- Knifeless™ Tape, 3M recommends using this product with 3M's 2-mil cast films and 3M™ Wrap Film Series 1080. See <http://knifelesstechsystems.com/Home.aspx> for details, including videos and ordering information.
- Snap-off cutting knives or razor blades in safety holders (never use a carbide tip blade which can cut through glass)
- Industrial heat gun, or the equivalent, that is capable of attaining at least 500°F (260°C)
- Cotton gloves

<sup>1</sup> Available from 3M Commercial Solutions.

<sup>2</sup> Available from automobile supply houses handling DuPont or Sherwin Williams products.

<sup>3</sup> Available from chemical companies listed under "Solvents" in the Yellow Pages or mail order chemical firms, such as E. H. Sargent and Co. and Fisher Scientific.

<sup>4</sup> Available from Knifeless Technology Systems, Inc.

## 6. Application Temperature and Environment

### A. Best Application Temperature

For the best success with the films recommended for vehicle graphics, always apply the graphics when the air and vehicle surface are both above 60°F (16°C).

### B. Cool Application Conditions

If the temperature is too cool, move the vehicle indoors to bring its surface temperature up to at least the minimum application temperature.

Below the recommended minimum application temperature:

- Films are not able to maintain the elevated temperatures required for stretching; films will cool too quickly.
- The initial bond of the adhesive may be insufficient to ensure the film stays adhered.
- Moisture may condense on the vehicle surface if the temperature of the vehicle surface is below the dew point.
- In very humid conditions, it may be difficult to keep the substrate dry.

### C. Very Warm Application Conditions

If the temperature is too warm, move the vehicle indoors or into the shade and be sure the vehicle surface cools to below 90°F (32°C) before beginning the installation.

Above the recommended maximum application temperature:

- Graphics may pre-adhere thereby trapping air.
- The adhesive will be more aggressive.
- Controltac films may lose their positionability feature.
- The film may stretch.

### D. Post-Application Conditions

After application of the graphic, keep the vehicle temperature above 60°F (16°C) for as long as possible—at least 12 hours is ideal—before exposing the vehicle to either a cold or wet climate; this strengthens the graphic's bond to the contoured areas.

## 7. How to Reduce or Avoid Film Lifting

### A. Use 3M™ Tape Primer 94

Identify all areas on the vehicle where the graphics may tend to lift such as in concave channels, inside wheel wells and other underside areas of the vehicle.

1. Use primer 94 to promote better film adhesion where the film will be stretched.
  - In **concave channels**, apply a thin layer of primer over most of the concave area. Allow the primer to dry for five minutes.
  - When going around **convex areas**, apply a thin layer of primer at the outer edges of the curve to prevent film edge lifting. Allow the primer to dry for five minutes.
  - For the most effective bond and to avoid contamination, install the graphic within one hour after applying the primer.

[Video](#)

Watch a demonstration on how to use 3M's primer 94.

## B. Apply to Flat Areas First

2. Apply the film to flat areas of the vehicle first.

Avoid areas at the underside of the vehicle. These areas are usually too difficult to clean sufficiently for proper film adhesion.

## C. How to Use Heat Soften Film

3. Use heat to soften the film when stretching it around and into complex curves.

- a. Use as much heat as possible to soften the film without burning it. Typically, heat the film to about 150-180°F (65-82°C) for convex and concave areas including bumpers and channels.

Note: Film IJ380Cv3 are much softer films and need to be heated to only 120-130°F (50-55°C).

- b. Film cools within seconds so gently stretch the film immediately after the heat source is removed. The film should be too hot to touch with unprotected hands; be sure to wear cotton gloves.

- c. To apply film into concave channels, use cotton gloves or use a squeegee with a low friction sleeve or Scotchmate loop material applied to the edge. Press the heated and softened film into the middle of the channel first so that the film is stretched evenly across the channel. See FIGURE 1.

**FIGURE 1**  
Technique For Stretching  
Heated Film into Channels

Right

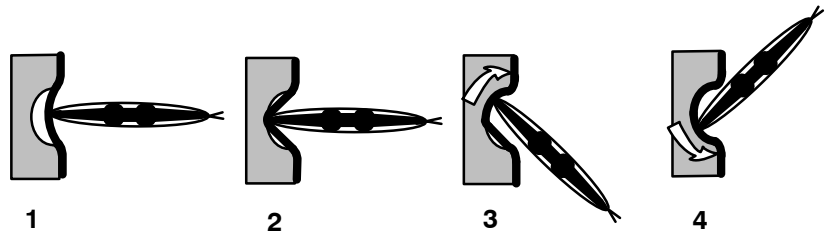

Wrong



- d. Another option for deep channels is to use the 3M licensed vehicle channel applicator tool VCAT-2 or the Roller L tool to effectively work the heated film into deep channels. See FIGURE 2. Proper technique includes bridging the film over the channels, heating the film to about 150-180°F (65-82°C), and then working it into the channels. Note that film IJ380Cv3 needs to be heated to only 130°F (55°C). It is essential that you refer to [Product and Instruction Bulletin VCAT-2](#) for complete details.

**FIGURE 2**  
Technique For Stretching  
Heated Film into Channels



Tool V-Cat2



Tool Roller L

[Video](#)

Watch a demonstration on how to stretch heated film into channels.

**D. Graphics Printed with UV cured Inkjet Inks and UV cured clears are Heat Sensitive!**

UV cured inkjet inks and UV cured clears may crack if too much heat is used during graphic application to complex curves and deep contours as well as around rivets. When using heat during application, make sure the film surface temperature does not exceed 212°F (100°C). For best results, always do a test application of a printed graphic to determine how much heat can be used without damaging the image.

3M recommends using additional heat in the post-application process for vehicle wraps. During this process, 3M only recommends using a heat gun to make sure the film surface temperature does not exceed 212°F (100°C).

**E. Use Heat in Post-Application**

4. After the film has been applied, apply heat to the graphic to reduce the internal stress in the vinyl film.
  - a. Adjust the heat source so that the film temperature reaches 200 to 225°F (93 to 107°C).
  - b. Move the heat source slowly across the stretched film surface.
  - c. For best performance, press the stretched areas of film with 3M Roller S while the vinyl is still hot. This helps fully wet-out the adhesive onto the substrate and reduces the risk of lifting. See FIGURE 3.

**FIGURE 3**  
Use Roller S for Post-Application Finishing to Help Prevent Lifting



**F. Stretching in Deep Channels**

5. Cutting the film in deep channels relieves the inherent stress of the applied film. This technique is used with films for longer term applications, such as film 180 or 180C. Cutting is *not* recommended for shorter-term films with changeable adhesive, such as film 3552C.

In general, cutting is not necessary if the previous application techniques have been followed unless the film is expected to lift in the high stress areas or non-recommended films were used.

**G. Cutting Technique**

- a. Identify areas where the film is stretched to greater than 130% (or 150% for films IJ380 and IJ380Cv3 with solvent-based inks and for film LX480Cv3/SV480Cv3) of the original film dimension *and* the radius of the channel is 1/4 inch or less. See FIGURE 4. To determine the percent of stretch, measure the travel distance through the channel and divide by the length across the channel (example:  $1.8'' / 1.0'' = 180\%$ ). See FIGURE 5.

**FIGURE 4**  
Checking Radius of Channel

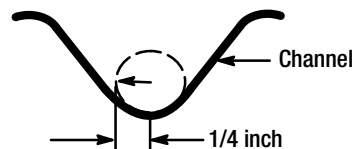

**FIGURE 5**  
Determine Percent of Stretch

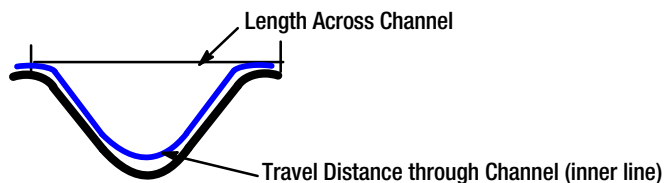



- b. Cut the film near the top of the concave curve and lay into the channel without excessive stretching; this avoid lifting of the film. Some paint will be exposed in the finished application, but should not be visible in a well planned cut. See FIGURE 6.

**FIGURE 6**  
Cut the Film in the Channel

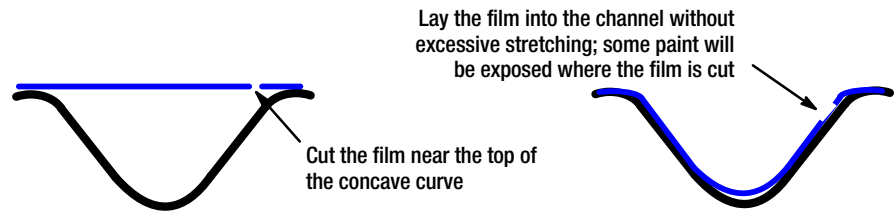

## 8. Application Techniques

### A. Application Procedure

1. Use firm, even application pressure.
2. Use overlapping squeegee strokes to be sure you don't miss any areas. Firm, consistent pressure with an applicator tool must be applied over all parts of the graphic to bond the adhesive to the substrate. A missed area leaves wrinkles and bubbles in the applied film. These are areas where premature film failures may occur.
3. Carefully cut the film at all seams in vehicle body panels, being sure not to scratch the paint. Seams on vehicles flex as the vehicle moves. If they are not cut, the graphics will pull away from the seam, resulting in premature failure.
4. Strive for a bubble-free application. Although puncturing air bubbles improves the appearance of the graphic, it can contribute to premature graphic failure if the film is torn or cut rather than neatly punctured.
5. Re-squeegee all edges and overlaps to ensure good adhesion before releasing the vehicle for use.

### B. Avoid These Applications

- **Do not apply film in any way that restricts the safe operation of emergency window exits.** See the most current [Instruction Bulletin 5.4](#) for details.
- Avoid applying graphics to unpainted plastic substrates. 3M does not warrant the application of film to textured plastic substrates under any circumstances. However, if you wish to try, using heat and a rivet brush to conform the film to the texture may be satisfactory for an unwarranted application.
- Do not apply the films to rubber, silicone or flexible plastics. The adhesive on the recommended films does not adhere to these materials.



---

#### ***Special Bus Application Safety Information***

The Office of Vehicle Safety Compliance of the U.S. National Highway Traffic Safety Administration (NHTSA) has asked for 3M's assistance in communicating an important safety concern. NHTSA has observed that graphic films used for bus wraps could be, and in some cases have been, applied in such a way as to block or restrict emergency window exits.

#### ***Penalties For Non-compliance***

Failure to trim film away from rubber gaskets surrounding emergency exit windows can render an emergency exit inoperable. This is a violation of Title 49 United States Code section 30122. Substantial civil penalties as set forth in Title 49 United States Code section 30165 may be incurred for such a violation.

---

### C. Important Information in Instruction Bulletin 5.5

Refer to [Instruction Bulletin 5.5](#) for:

- Graphic placement
- Making film overlaps
- Registering the graphic
- Removing the adhesive's liner
- Application sequences (that apply to your type of graphic)

## D. Vehicle Windows

### (1) Application Restrictions

3M's policy is not to support applications of perforated window graphic film when a driver's view is obstructed and/or where local laws prohibit its use.

The following uses and applications are specifically NOT recommended or warranted for perforated graphic film:

#### Restrictions for Vehicle Window Graphics

- Graphics that are not trimmed away from all openings of any emergency window exit.
- Windows with windshield wipers.
- Application to windows that crank or roll down, rubber moldings or window gaskets
- Non-laminated or improperly laminated film on exterior windows that require an optically clear view.

#### WARNING

Applications that require an optically-clear view, such as vehicle window exteriors, must be laminated with [3M™ Scotchcal™ Optically Clear Overlaminate 8914](#). Failure to apply this overlaminate could result in obstructed or impaired viewing when the product becomes wet.

#### CAUTION

Some states have laws or regulations requiring minimum light transmission that may limit or preclude the use of this product on regulated vehicle windows, which may include passenger vehicles and vans. The user is responsible for determining and complying with all applicable standards.

## E. Safety Guidelines for Applying Vehicle Window Graphics

- Before applying film, open all emergency exit windows to determine exactly where graphics must be trimmed to ensure no interference with the operation of these windows.
- If an emergency window is non-functioning, it is your responsibility to alert the bus maintenance personnel before proceeding.
- Always trim the film 1/8 - 1/4 inch (3 to 6 mm) away from all rubber gaskets. Do not apply film over rubber gaskets.
- Do not allow any graphic film, whether applied to windows or bus body, to overlap the opening of an emergency window exit.
- After graphic installation is completed, ensure that all emergency window exits are fully functional.

## F. Sizing the Window

Measure the window opening and the graphic to make sure that it fits on the window. Apply the graphic and then cut away a margin of 1/8 to 1/4 inch (3 to 6 mm) all around the graphic. See FIGURE 7.

Do NOT apply the film to any rubber gaskets or parts on the buses. This minimizes the chance of the graphic lifting, or absorbing water that may collect in the window edge.

Do NOT allow any film to overlap the openings for any emergency window exits, which can prevent the window from operating properly in an emergency.

**FIGURE 7**  
Leave a Space All Around the Window

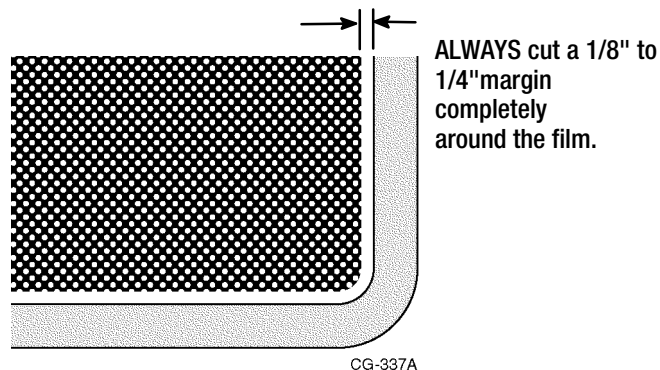

## G. Applying Perforated Window Graphic Film

Note: Before applying the film, be sure you understand what method of edge sealing will be used. See the next page.

1. Make sure that the glass is clean. Some glass has coatings that can prevent the graphic from adhering adequately. See [3M Instruction Bulletin 5.1](#) for details on cleaning and how to determine whether there is a coating.
2. Always use a dry application method. Refer to [3M Instruction Bulletin 5.5](#).
3. Use a low-friction sleeve on the plastic applicator to prevent scratching.
4. During application:
  - Do not stretch the film into the window well or onto the window itself, which causes tension that can result in the graphic shrinking and its edges curling.
  - Cut the film to the approximate shape of the window before squeegeeing it. To do this, tack down the film in the center of the window, cut the graphic to shape, and squeegee the film to the window.
  - Do not use a heat source directly on the window. This can cause the film to shrink and its edges to curl.
5. When the application is completed and all window film has been trimmed, RESQUEEGEE ALL EDGES to ensure the best adhesion.

## H. Painted Metal Surfaces Between Windows

If window graphic film is applied to narrow painted metal surfaces between windows, the image may not look consistent. To maintain a consistent image, an opaque 3M vinyl film may be applied to the surfaces between windows before the perforated film is applied.

## I. Seaming Side-by-Side Panels

If two panels are designed to meet side by side on a window, carefully trim the images so that the panels meet and form a butt seam. Do NOT overlap the panels. Always trim before starting the application. Do NOT cut the film while it is on the window as this may permanently scratch some window surfaces.

## J. Edge Sealing

Edge sealing is required for all perforated window graphics in order to be warranted. Edge sealing improves the resistance to environmental damage and enhances the durability of the graphics. You can use one of these two options:

- Order 3M™ Edge Sealer 8914, which is 1/2 inch (13 mm) wide rolls of overlamine 8914 from 3M. Use part number 75-3469-0233-3 and specify 1/2 inch x 50 yard (13 mm x 43 m) rolls.
- Alternately, cut 1/2 inch (13 mm) rolls from your inventory of overlamine 8914.

### (1) Seal Edges with Strips of Overlamine

*This method can be used whether your graphic has overlamine 8914 or a screen printed clear coat applied.*

Apply a 1/2 inch (13 mm) strip of overlamine 8914 so each strip evenly straddles the perforated film and substrate. Overlap the corners. See FIGURE 8 and FIGURE 9.

FIGURE 8  
Applying 3M™ Edge Sealing Tape 8914

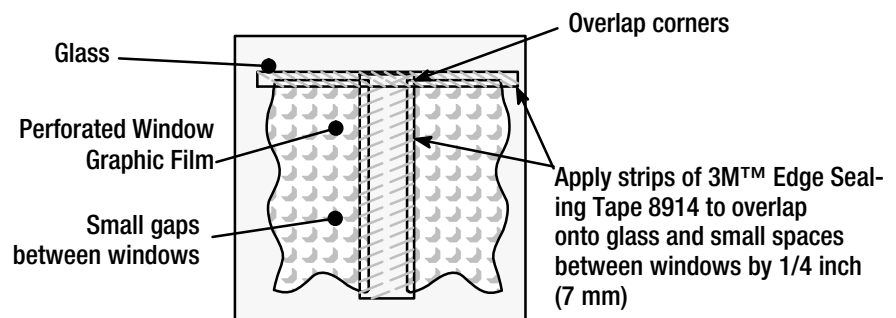

### **Important Note!**

Never allow film or overlamine or edge sealer to touch the rubber window molding.

**FIGURE 9**  
**Avoid Rubber Moldings**

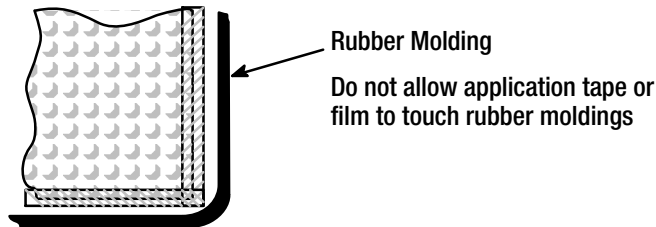

## 9. Removal

Refer to the film's Product Bulletin for information on its removability, and [Instruction Bulletin 6.5](#) for additional details on film removal.

Removal of short-term graphics with changeable adhesives will leave little or no adhesive residue. These films will not damage a soundly painted surface or a previously applied 3M vinyl graphic unless the surface was corroded, rusted, blistered, scratched or previously damaged, or if it was damaged since the graphic application.

To remove a changeable film, grasp a corner of the graphic and peel it back at approximately a 120 degree angle. In areas where tape primer 94 is used, some adhesive will remain on the vehicle. Any remaining adhesive and tape primer 94 can be removed with an adhesive cleaner such as 3M's citrus base industrial cleaner.

## 10. Warranty Information

The [3M Graphics Warranties Brochure](#) at 3Mgraphics.com, along with the applicable film Product Bulletins, provide the details to any warranty offered for the 3M graphics products described in this Bulletin.

### A. Paint Staining Limitation

3M does not warrant vehicle paint staining that may be visible after removing an inkjet printed graphic with an overlamine. To reduce the risk of this problem, always remove the graphics by the end of the Warranty Period.

## 11. Disclaimer

The information contained and techniques described herein are believed to be reliable, but 3M makes no warranties, express or implied, including but not limited to any implied warranty of merchantability or fitness for a particular purpose.

## 12. Limitation of Liability

Except where prohibited by law, 3M SHALL NOT UNDER ANY CIRCUMSTANCES BE LIABLE TO PURCHASER OR USER FOR ANY DIRECT, INDIRECT, SPECIAL, INCIDENTAL, OR CONSEQUENTIAL DAMAGES (INCLUDING, BUT NOT LIMITED TO, LABOR, NON-3M MATERIAL CHARGES, LOSS OF PROFITS, REVENUE, BUSINESS, OPPORTUNITY, OR GOODWILL) RESULTING FROM OR IN ANY WAY RELATED TO SELLER'S PRODUCTS OR SERVICES. This limitation of liability applies regardless of the legal or equitable theory under which such losses or damages are sought including breach of contract, breach of warranty, negligence, strict liability, or any other legal or equitable theory.

## 13. Bulletin Change Summary

Modified and new content is marked with a black bar in the margin. Added important new information in Section 10B regarding the Relative Stretching Capabilities of Common Wrap Film Graphic Constructions. Added video to show how to stretch heated film into channels. The 3M Related Literature section has been replaced by direct links to the most current versions of Bulletins or warranty information you may need to successfully use this product. All links are blue underlined text.

**PLEASE NOTE THESE REQUIRED FORMS on the following pages:**

**3M Auto and Van Graphics Pre-installation Inspection Record pg 13,14**

**3M Bus and Mini-Bus Graphics Pre-installation Inspection Record pg 15,16**



### Commercial Solutions

3M Center, Building 220-12E-04  
St. Paul, MN 55144 USA  
General & Technical  
1-800-328-3908  
Fax 1-651-736-4233

### 3M Canada

PO Box 5757  
London, Ontario  
Canada N6A 4T1  
General 1-800-265-1840  
Fax 519-452-6245

### 3M México S.A. de C.V.

Av. Santa Fe No. 55  
Col. Santa Fe, Del. Alvaro Obregón  
México D.F. 01210  
General 5255-5270-0400  
Fax 5255-5270-2277

### 3M Puerto Rico, Inc.

350 Chardon Avenue  
Suite 1100  
San Juan, PR 00918  
General 787-620-3000  
Fax 787-620-3018

*3M, Comply, Controltac, Envision, Scotchcal, Scotchmate, and Scotchlite are trademarks of 3M Company. Dawn and Joy are registered trademarks of Proctor and Gamble.; Sherwin-Williams Clean is a trademark of Sherwin-Williams Company; Knifeless is a trademark of Knifeless Technology Systems. All other trademarks are the property of their rightful owners.*

Note: Complete both pages of this Pre-installation Inspection Record, using a separate record for each vehicle, before each new graphic installation and between subsequent graphic installations on the same vehicle.

## Installer Requirements

1. Carefully and thoroughly examine each vehicle and record all potential problem areas prior to installing the graphics. We recommend washing the vehicle so that potential problem areas are easily seen.
2. Ensure that the paint is sound so that graphics will have good adhesion to the paint. For the purpose of this program, "sound paint" is defined as paint that is free of defects (see the "Defects" bullet below).

Circle all areas on the following diagram where your inspection shows that the paint may be unsound, the graphic may adhere poorly, or graphic removal may damage the vehicle paint. This includes:

- Defects: loose paint, dents, rough surface, fillers used for damage, rust or blistered paint.
- Areas where water can collect, which are more likely to rust, resulting in paint adhesion problems.

Note: Primer, which does not outgas, may be applied to bad paint spots on the vehicle to prepare it for another graphic wrap. However, this must still be considered a problem area and must be documented on the Pre-installation Inspection Record.

3. Photograph all areas that you circled on the diagram as exhibiting unsound paint.
4. Explain proper graphic maintenance to the Vehicle Owner/Operator. See Instruction Bulletin 6.5.
5. Complete the Pre-installation Inspection Record (see the next page of this document).
6. Make and distribute copies to all signing parties.
7. Maintain a file with the signed form and photographs.

## Warranty Claims and Exceptions

1. Failure to obtain a properly executed and signed Pre-installation Inspection Record (see the next page of this document) prior to graphic installation voids all expressed or implied 3M product warranties.
2. If the pre-inspection shows the paint is not free of defects, the owner of the vehicle waves all expressed or implied 3M product warranties.
3. 3M does not warrant vehicle paint staining that may be visible after removing an inkjet printed graphic with an overlamine. To reduce the risk of this problem, always remove the graphics by the end of the Warranty Period. See the 3M™ MCS™ Warranty for complete details at [www.3Mgraphics.com](http://www.3Mgraphics.com).
4. To make a claim, contact 3M Commercial Graphics Quality Direct at 1-800-511-3705 or go to [www.3Mgraphics.com/qualitydirect](http://www.3Mgraphics.com/qualitydirect). Be prepared to send in:
  - A piece of the 3M film exhibiting the defect.
  - A properly executed and signed 3M Pre-installation Inspection Record, including any available photographs.

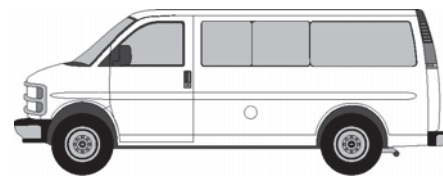
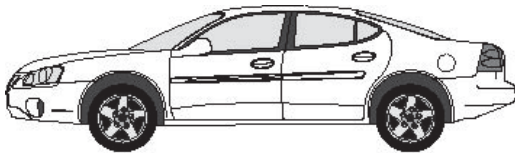

**Circle all areas where the paint may be unsound. Mark only one vehicle type.**

(Diagrams courtesy of Digital Auto Library, 1-888-843-1325 or [www.digitalauto.on.ca](http://www.digitalauto.on.ca))

**COMPLETE THIS FORM, PROVIDE A COPY FOR EACH SIGNER  
AND RETAIN WITH PHOTOGRAPHS IN CASE OF A CLAIM.**

Please print except in signature boxes.

<b>AUTOMOBILE OWNER/OPERATOR</b>
COMPANY NAME
CONTACT NAME
STREET ADDRESS
CITY / STATE / ZIP
AREA CODE / PHONE NUMBER
<b>GRAPHICS PRINTER</b>
COMPANY NAME
CONTACT NAME
STREET ADDRESS
CITY / STATE / ZIP
AREA CODE / PHONE NUMBER
<b>GRAPHICS INSTALLER</b>
COMPANY NAME
CONTACT NAME
STREET ADDRESS
CITY / STATE / ZIP
AREA CODE / PHONE NUMBER

<b>AUTOMOBILE INFORMATION</b>	
LICENSE NUMBER	STATE
AUTOMOBILE YEAR, MAKE AND MODEL	
VIN NUMBER	
AUTOMOBILE OWNER/OPERATOR	
PRE-INSPECTION: (see the previous page of this bulletin for inspection requirements)	
<input type="checkbox"/> PASSED (DATE: _____ BY: _____) <input type="checkbox"/> FAILED (Owner waives all product warranties if graphics are applied)	
PHOTOGRAPHS OF POTENTIAL PROBLEM AREAS:	
<input type="checkbox"/> YES (DATE: _____ BY: _____) <input type="checkbox"/> NO	
<b>GRAPHIC CONSTRUCTION AND INSTALLATION INFORMATION</b>	
INSTALLATION DATE	
GRAPHIC COVERAGE	
<input type="checkbox"/> FULL <input type="checkbox"/> REAR ONLY <input type="checkbox"/> TRUNK ONLY <input type="checkbox"/> DRIVER SIDE ONLY <input type="checkbox"/> PASSENGER SIDE ONLY	
SUBSTRATE CLEANED AND PREPARED ACCORDING TO 3M RECOMMENDATIONS:	
<input type="checkbox"/> YES (DATE: _____ BY: _____)	
FILM & GRAPHIC PROTECTION USED	
<b>SIGNATURES OF ALL PARTIES</b>	
INSTALLER	/ DATE
AGENCY REPRESENTATIVE	/ DATE
AUTOMOBILE OWNER/OPERATOR	/ DATE

# 3M Bus & Mini-Bus Graphics Pre-installation Inspection Record

## Installer Requirements

Note: Complete both pages of this Pre-installation Inspection Record, using a separate record for each vehicle, before each new graphic installation and between subsequent graphic installations on the same vehicle.

1. Carefully and thoroughly examine each vehicle and record all potential problem areas prior to installing the graphics. We recommend washing the vehicle so that potential problem areas are easily seen.
2. Ensure that the paint is sound so that graphics will have good adhesion to the paint. For the purpose of this program, "sound paint" is defined as paint that is free of defects (see the "Defects" bullet below).

Circle all areas on the following diagram where your inspection shows that the paint may be unsound, the graphic may adhere poorly, or graphic removal may damage the vehicle paint. This includes:

- Defects: loose paint, dents, rough surface, fillers used for damage, rust or blistered paint.
- Areas where water can collect, which are more likely to rust, resulting in paint adhesion problems.

Note: Primer, which does not outgas, may be applied to bad paint spots on the vehicle to prepare it for another graphic wrap. However, this must still be considered a problem area and must be documented on the Pre-installation Inspection Record.

3. Photograph all areas that you circled on the diagram as exhibiting unsound paint.
4. Explain proper graphic maintenance to the Vehicle Owner/Operator. See Instruction Bulletin 6.5.
5. Complete the Pre-installation Inspection Record (see the next page of this document).
6. Make and distribute copies to all signing parties.
7. Maintain a file with the signed form and photographs.

## Warranty Claims and Exceptions

1. Failure to obtain a properly executed and signed Pre-installation Inspection Record (see the next page of this document) prior to graphic installation voids all expressed or implied 3M product warranties.
2. If the pre-inspection shows the paint is not free of defects, the owner of the vehicle waves all expressed or implied 3M product warranties.
3. 3M does not warrant vehicle paint staining that may be visible after removing an inkjet printed graphic with an overlaminate. To reduce the risk of this problem, always remove the graphics by the end of the Warranty Period. See the 3M™ MCS™ Warranty for complete details at [www.3Mgraphics.com](http://www.3Mgraphics.com).
4. To make a claim, contact 3M Commercial Graphics Quality Direct at 1-800-511-3705 or go to [www.3Mgraphics.com/qualitydirect](http://www.3Mgraphics.com/qualitydirect). Be prepared to send in:
  - A piece of the 3M film exhibiting the defect.
  - A properly executed and signed 3M Pre-installation Inspection Record, including any available photographs.

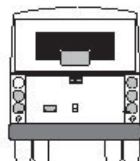
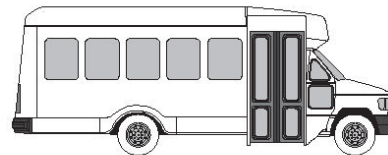
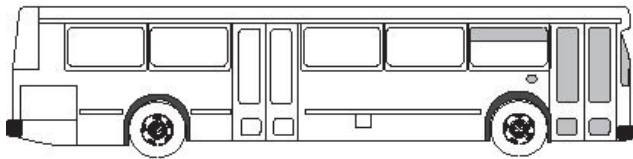
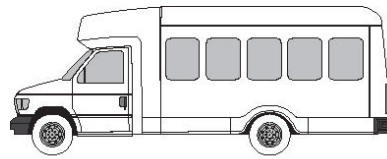
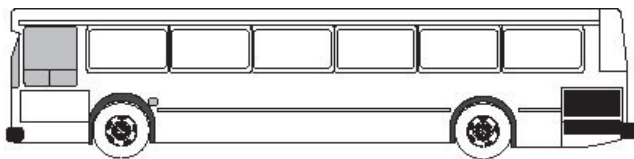

**Circle all areas where the paint may be unsound. Mark only one vehicle type.**

(Diagrams courtesy of Digital Auto Library, 1-888-843-1325 or [www.digitalauto.on.ca](http://www.digitalauto.on.ca))

# 3M Bus & Mini-Bus Graphics Pre-installation Inspection Record

**COMPLETE THIS FORM, PROVIDE A COPY FOR EACH SIGNER  
AND RETAIN WITH PHOTOGRAPHS IN CASE OF A CLAIM.**

Please print except in signature boxes.

<b>BUS OWNER/OPERATOR</b>
COMPANY NAME
CONTACT NAME
STREET ADDRESS
CITY / STATE / ZIP
AREA CODE / PHONE NUMBER
<b>GRAPHICS PRINTER</b>
COMPANY NAME
CONTACT NAME
STREET ADDRESS
CITY / STATE / ZIP
AREA CODE / PHONE NUMBER
<b>GRAPHICS INSTALLER</b>
COMPANY NAME
CONTACT NAME
STREET ADDRESS
CITY / STATE / ZIP
AREA CODE / PHONE NUMBER

<b>BUS INFORMATION</b>
LICENSE NUMBER
BUS YEAR, MAKE AND MODEL
VIN NUMBER
BUS OWNER/OPERATOR
PRE-INSPECTION: (see the previous page of this bulletin for inspection requirements) <input type="checkbox"/> PASSED (DATE: _____ BY: _____) <input type="checkbox"/> FAILED (Owner waives all product warranties if graphics are applied)
PHOTOGRAPHS OF POTENTIAL PROBLEM AREAS: <input type="checkbox"/> YES (DATE: _____ BY: _____) <input type="checkbox"/> NO
<b>GRAPHIC CONSTRUCTION AND INSTALLATION INFORMATION</b>
INSTALLATION DATE
GRAPHIC COVERAGE <input type="checkbox"/> FULL <input type="checkbox"/> BODY ONLY <input type="checkbox"/> WINDOWS ONLY <input type="checkbox"/> QUEEN PANELS ONLY <input type="checkbox"/> KING PANELS ONLY
SUBSTRATE CLEANED AND PREPARED ACCORDING TO 3M RECOMMENDATIONS: <input type="checkbox"/> YES (DATE: _____ BY: _____)
FILMS/OVERLAMINATES USED
<b>SIGNATURES OF ALL PARTIES</b>
INSTALLER _____ / DATE _____
AGENCY REPRESENTATIVE _____ / DATE _____
BUS OWNER/OPERATOR _____ / DATE _____